

MODEL FEATURES

	CZ	CRZ	CRIZ	CHZ	CHZ VISUAL	CDZ	CZ 12V
PILOT LIGHT	●	●	●	●	●	●	●
BACKDRAFT SHUTTER	●	●	●	●	●	●	●
ADJUSTABLE RUN-ON-TIMER (1-30 MIN)		●		●	●	●	*
AUTOMATIC TIMER			●				
ADJUSTABLE HUMIDISTAT				●	●		
DETECTOR MOVEMENT						●	
BALL BEARINGS	●	●	●	●	●	●	●
WIRING DIAGRAM**	2, 3	4, 5	4, 5	1, 4	1, 4	1	6

* Using CT-12/14R transformer.

** See section of Wiring Diagrams.

PERFORMANCE CURVE

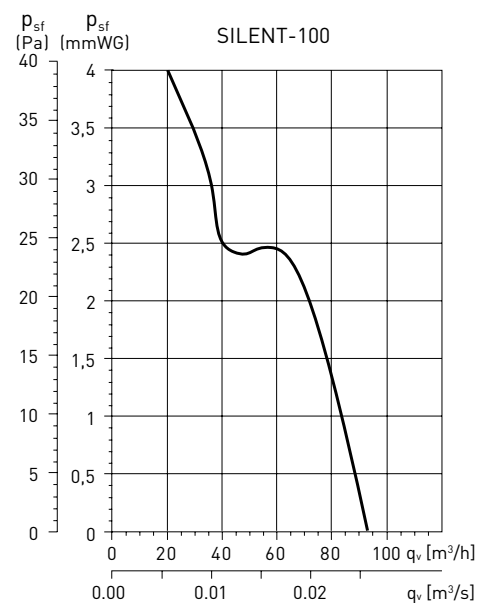

TECHNICAL CHARACTERISTICS

Model	Speed (rpm)	Abs. power at free discharge (W)	Voltage (V) 50 Hz	Sound pressure level* (dB(A))	Airflow at free discharge (m³/h)	Insulation/ IP	Ø duct (mm)	Weight (kg)
SILENT-100	2400	8	230	26,5	95	Class II / IP45	100	0,57
SILENT-100 12V	2320	13	12	26,5	95	Class III / IP57	100	0,57

* Sound pressure level measured at 3 m at free air conditions.

DIMENSIONS (mm)

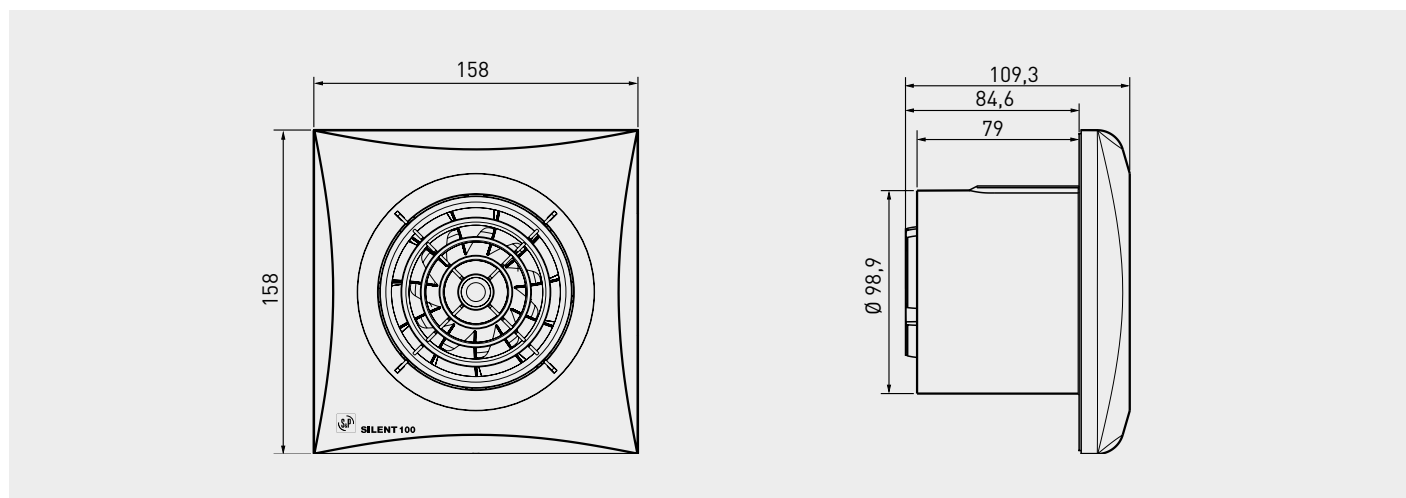

ACCESSORIES



GSA-M0 100
Flexible aluminium ducting.



GRA-75
Aluminium exterior grille.



WALL KIT
Fixed shutter and telescopic duct. (200 to 420 m).



CX-80/125
Worm drive ducting clip.



PER-100W
Back draft shutter.



WINDOW KIT 100
Accessory to allow SILENT-100 in a window.